



SERVICE BULLETIN

SB00020 Rev A

Page 1 of 4

Cub Crafters, Inc. Considers Compliance Mandatory

EFFECTIVE DATE: This SERVICE BULLETIN is effective **February 6, 2012.**

SUBJECT: ELEVATOR CONTROL SYSTEM UPGRADE.

MODELS AFFECTED: CC11-100 AND CC11-160 S/N 00001 THROUGH S/N 00197.

COMPLIANCE TIME: WITHIN 10 FLIGHT HOURS.

PURPOSE: TO INCREASE CONTROL SYSTEM SECURITY.

PURPOSE OF REVISION: ADD SPECIFIC INSTRUCTIONS FOR S/N 00001 THROUGH 00013.

WARRANTY: ALL AIRCRAFT WITHIN THE ONE-YEAR WARRANTY PERIOD WILL RECEIVE PARTS (IF NEEDED) AT NO CHARGE AND A LABOR REIMBURSEMENT OF UP TO TWO HOURS AT A RATE OF \$75/HOUR.

*** PARTS LIST:**

PART NUMBER	DESCRIPTION	QTY	QTY2*
SC80003-001	Elevator Horn Plate, LH	1	1
SC80003-002	Elevator Horn Plate, RH	1	1
SC80004-001	Elevator Horn Spacer	1	1
SC80005-001	Front Stick Reinforcement	1	-
SC94006-001	Replacement Front Stick	-	1
AN364-428A	Nut	1	1
AN4-3A	Bolt	1	1
MS35489-35	Grommet	1	-
VP6007-003	Solder Sleeve	6	6
HDW-HIX-1/2	Heat Shrink	12"	12"
HDW-HIX-3/8	Heat Shrink	12"	12"

*QTY2 column is for serial numbers 00001 – 00013 all else use QTY column.

INSTRUCTIONS:

For aircraft S/N 00001 through 00146:

1. If the torque tube was replaced while complying with SB00015 then proceed directly to the section for all aircraft.

Cub Crafters, Inc. Considers Compliance Mandatory
--

2. If the torque tube was not replaced previously then replace the torque tube per SB00015 before going to the section for all aircraft.

For aircraft S/N 00001 through 00013:

1. Remove the bolt from the bottom of the front control stick and lift the stick off. To do so disconnect the electronic trim wires as described below:
 - Label the wires on both sides, and then cut all six wires staggered (1 inch stagger) starting 1.5 inches past the seat base.
2. Send control stick back to Cub Crafters, Inc.
3. A replacement stick will be sent.
4. Install the solder sleeves, VP6007-003, and heat shrink per AC43.13-1.
5. Install the replacement control stick in the same manner the original was removed.

For aircraft S/N 00014 through 00146:

1. Remove the bolt from the bottom of the front control stick and lift the stick off. Disconnect the electronic trim wires as described below:
 - Label the wires on both sides, then cut all six wires staggered (1 inch stagger) on the stick side of the connector or if there isn't one starting 1.5 inches past the seat base.
 - Feed the wires through the hole into the center of the control stick so that the wires do not protrude out the side of the stick.
 - Remove the grommet from the control stick.
2. Mark off the bottom four inches of the stick and tape the area above.
3. Sand the bottom four inches lightly until the stick reinforcement, SC80005-001, slides on. Remove as little material as possible.
4. Install the reinforcement onto the front control stick; ensure that the trim wire holes line up between the stick and reinforcement.
5. Install the grommet, MS35489-35, into the hole to protect the wires.
6. Feed the wires back through the stick and install the solder sleeves, VP6007-003, and heat shrink per AC43.13-1. The ½ inch heat shrink covers up by the connector and the 3/8 inch heat shrink covers the solder sleeves.
7. Reinstall the control stick in the same manner it was removed.

Cub Crafters, Inc. Considers Compliance Mandatory

For All Aircraft:

1. Remove the elevator inspection covers, see Figure 1.

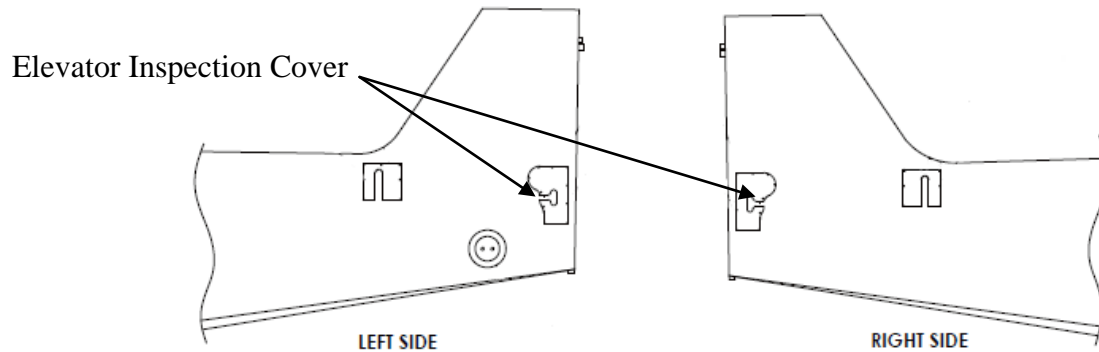

Figure 1 – Elevator Inspection Covers

2. Remove the upper bolt holding the two elevators together.
3. Install the elevator horn plates, SC80003-001 (left) and SC80003-002 (right), on either side of the elevator horn with the bent flange to the front. See Figure 2 for installation details.

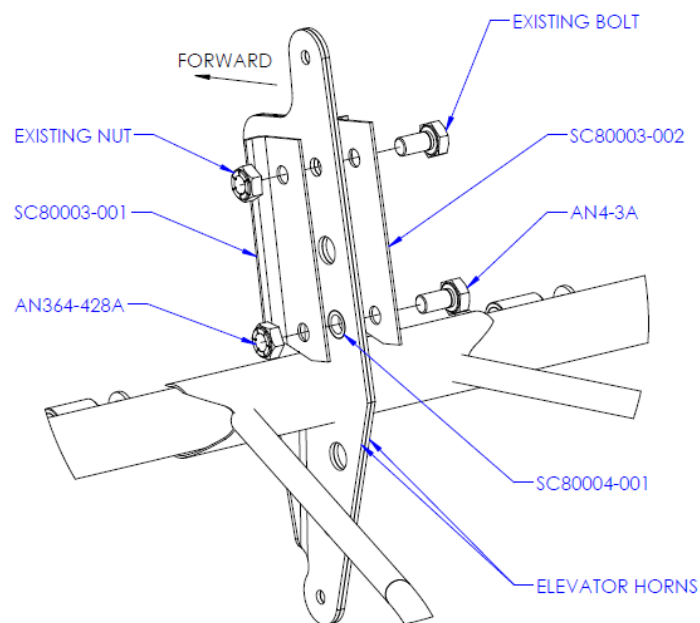

Figure 2 – Elevator Horn Plates Installation



Cub Crafters, Inc. Considers Compliance Mandatory

4. Inspect for full range of elevator and for clearance around the new, AN4-3A, bolt.
5. Install the elevator inspection covers.
6. Make a log book entry "Complied with per SB00020".

If you are no longer in possession of this aircraft, please forward this information to the present owner/operator and notify Cub Crafters, Inc. of the address of the current owner at:

1918 South 16th Avenue
Yakima, WA 98903-1212

Phone: (877) 484-7865 or (509) 248-9491
Fax: (509) 248-1421

Email: support@cubcrafters.com
Website: www.cubcrafters.com

Please include the aircraft registration number, serial number, current name, and address of the owner and/or operator.