

Cub Crafters, Inc. Considers Compliance Mandatory

EFFECTIVE DATE: This SERVICE BULLETIN is effective June 1, 2007

SUBJECT: UN-COMMANDED FLAP RETRACTION

MODELS AFFECTED: CC11-100 S/N00002 thru S/N00031

COMPLIANCE TIME: PRIOR TO NEXT FLIGHT

PURPOSE: THE FLAP LOCKING MECHANISM HAS THE POSSIBILITY OF DISENGAGING CAUSING UN-COMMANDED FLAP RETRACTION.

PARTS LIST:

<u>PART</u>	<u>DESCRIPTION</u>	<u>QTY</u>
SC32204-001	FLAP HANDLE LOCK REV. F	1

INSTRUCTIONS:

Remove old SC32204-001 part and replace with SC32204-001 revision F.

FLAP HANDLE LOCK REPLACEMENT PROCEDURE:

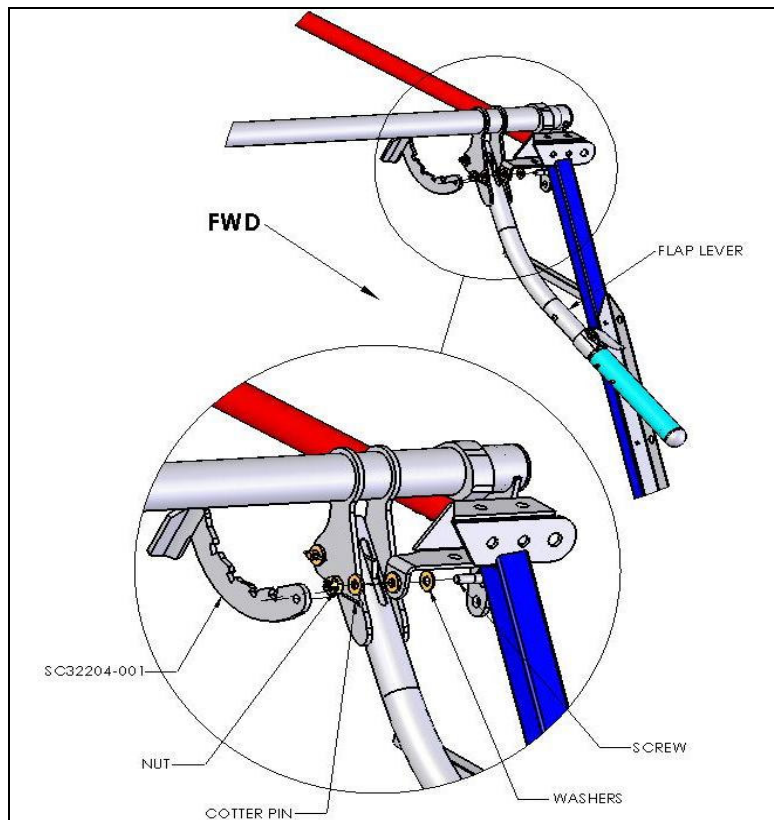

Figure 1

Cub Crafters, Inc. Considers Compliance Mandatory

1. Remove existing SC32204-001 by removing hardware as shown in Figure 1. Retain hardware and discard SC32204-001 and cotter pin.
2. Rotate flap lever arm fore and aft while applying pressure inboard or outboard to center and align flap cross bar with fuselage centerline as necessary.
3. Install SC32204-001 Revision F using same hardware and new cotter pin (AN380-2-2). SC32204-001 should be centered thru flap lever slot (see Figure 2). Additional washers (AN960-10 or AN960-10L) may be used to shim SC32204-001 to achieve center position. Do not use more than 4 washers per side to shim.

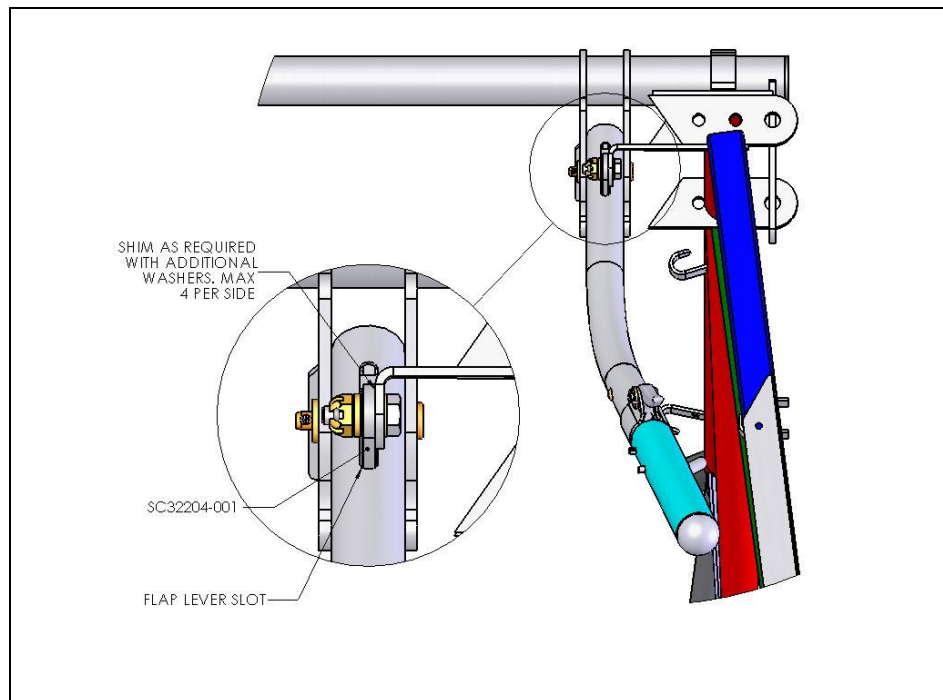

Figure 2

4. Ensure flaps work properly and all positions lock. Ensure no interference is occurring between flap lever and fuselage or any other components.
 5. Make logbook entry "Service Bulletin SB00005 complied with".
- If any discrepancies found, Contact Cub Crafters, Inc. prior to next flight.