



# SAFETY ALERT SA0002

**Cub Crafters, Inc. Considers Compliance Mandatory 10/02/06**

**EFFECTIVE DATE:** This Safety Alert is effective October 2, 2006

**SUBJECT:** Engine Mount and Jury Strut Modification

**MODELS AFFECTED:** CC11-100 S/N CC11-00001 thru CC11-00003.

**COMPLIANCE TIME:** Prior to Next Flight

**PURPOSE:** Modify Engine Mount and Jury Strut Installation

**PARTS LIST:**

<u>PART DESCRIPTION</u>	<u>QUANTITY</u>
ATTENUATOR, VISCO-ELASTOMERIC	4
GROMMET	4

**INSTRUCTIONS:**

## Engine Mount Modification

**NOTE:  
READ AND UNDERSTAND ALL INSTRUCTIONS BEFORE BEGINNING WORK.**

1. Remove upper and lower engine cowl per CC11-100 Maintenance Manual Section 6.3.14.
2. Working on one engine isolator mount at a time:
  - a. Remove nut. Bolt may also be removed, if necessary.
  - b. Remove forward isolator mount (See Figure 1).
  - c. Remove spacer (See Figure 2).
  - d. Remove rubber hose from spacer (See Figure 2).
  - e. Install supplied visco-elastomeric attenuator over spacer.
  - f. Install spacer in original position.

**NOTE:  
APPLY FORCE AS NECESSARY TO POSITION ENGINE AND ALLOW  
SPACER TO ENTER ENGINE MOUNT BORE.**

- g. Install forward isolator mount.
- h. Install bolt, if removed, and nut. Replace the nut if an AN363-720 self-locking metal stop nut was originally installed.
3. Complete Step 2 on remaining engine isolator mounts.
4. Torque all nuts to 175-190 in-lbs.
5. Install cotter pin AN380-3-3 in each nut, if necessary.
6. Install upper and lower engine cowl.

Cub Crafters, Inc. Considers Compliance Mandatory 10/02/06

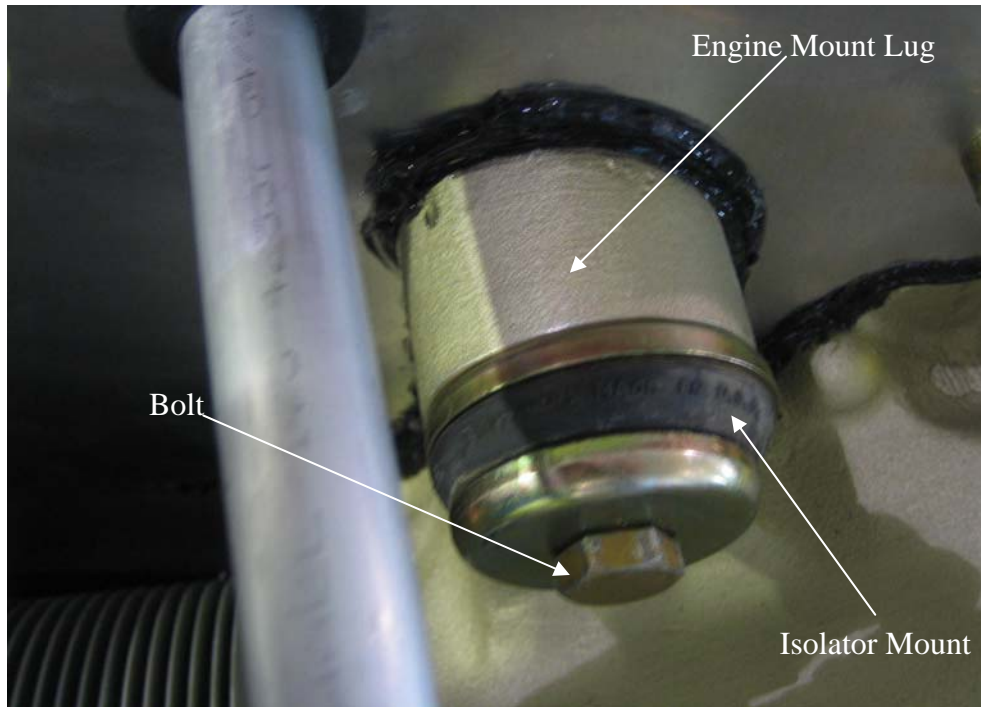

Figure 1

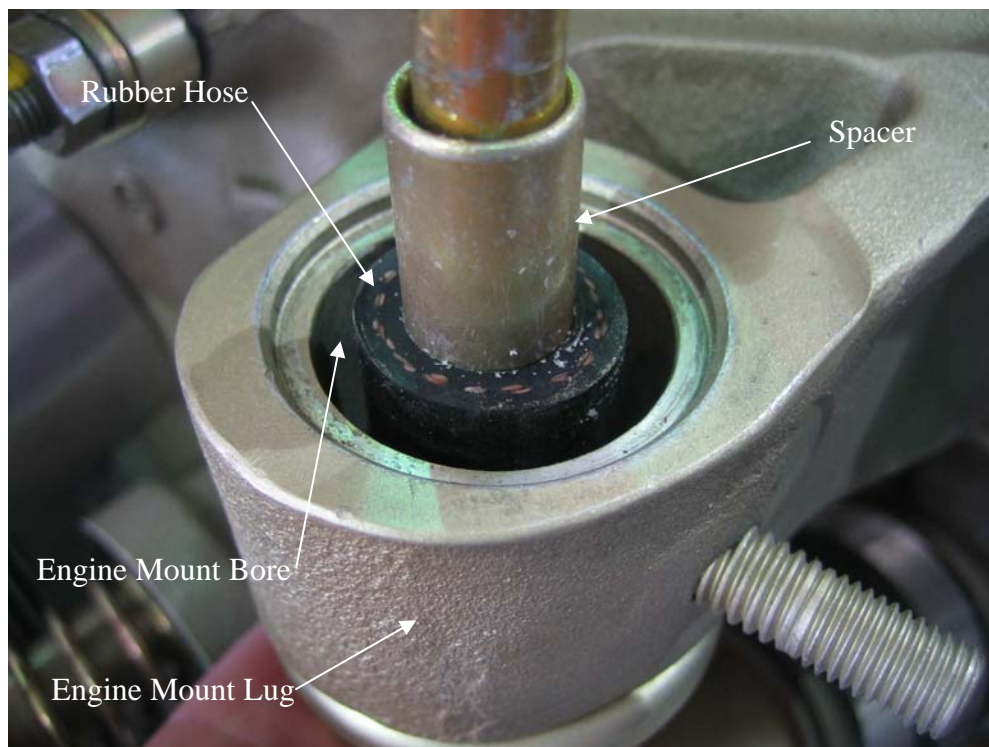

Figure 2

Cub Crafters, Inc. Considers Compliance Mandatory 10/02/06

### Jury Strut Modification

**NOTE:**

**Read and understand all instructions before beginning work.**

1. Disconnect upper and lower jury strut attachments.
2. Inspect upper and lower jury strut fitting for cracks. Replace, if cracked.
3. Open hole in lower jury strut fitting (P/N SC37204-001) to .250"  $\pm$ .003".
4. Install grommet in lower jury strut fitting (P/N SC37204-001). See Figure 3.
5. Install jury strut as noted (See Figure 3 and Figure 4) with hardware supplied.
6. Tighten nuts finger tight, advance to next castellation, and install cotter pin AN380-2-2.
7. Repeat steps 1-6 for opposite side.
8. Make a logbook entry showing that you have complied with Safety Alert SA0002.

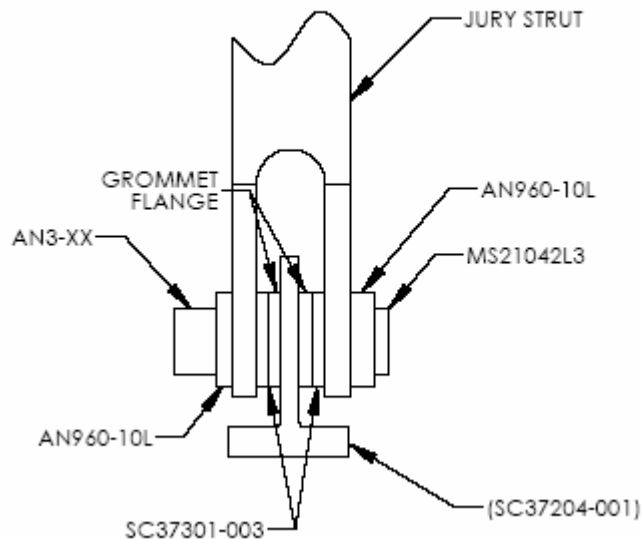

**Figure 3 - Lower Jury Strut Attachment Installation**

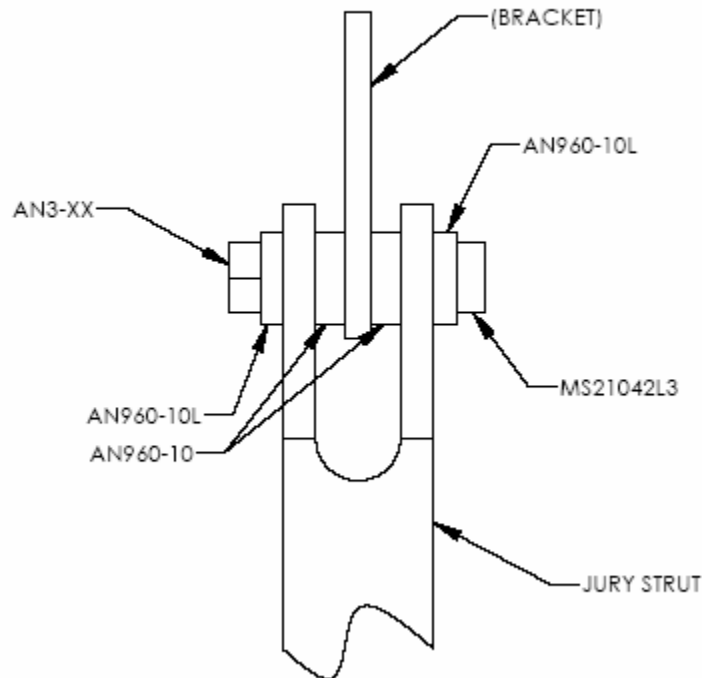

**Figure 4 - Upper Jury Strut Attachment Installation**

**NOTE:**

If you are no longer in possession of this aircraft, please forward this information to the present owner/operator. Notify Cub Crafters, Inc. of the current owner's address. Contact the customer service department at:

Cub Crafters, Inc.  
1918 S. 16th Avenue  
Yakima, WA 98903

Phone: (509) 248-9491

or e-mail Earl Barnes at [earlb@cubcrafters.com](mailto:earlb@cubcrafters.com)

Please include the aircraft registration number, serial number, and the name and address of the current owner/operator.